

**ATI**  
MINIEXCAVATOR

**12 PRO**



ALSO ELECTRICAL  
MODEL  
12Q & 15Q  
WITH 8 HOURS OF  
AUTONOMY

## SPECIFICATIONS

- QUINTALS / WEIGHT **12**
- MOTOR **KUBOTA D192F**
- HORSE POWER **10**
- **4 TIME FUNKTION**
- FUEL **DIESEL**
- FULL SPEED **2,2 KM/H**
- CHASSIS STRETCH **84.5-101.5 cm**
- SWING ARM
- GEAR PUMP
- SWING ANGLE **53°**
- OIL CAPACITY **28 Lt/min**

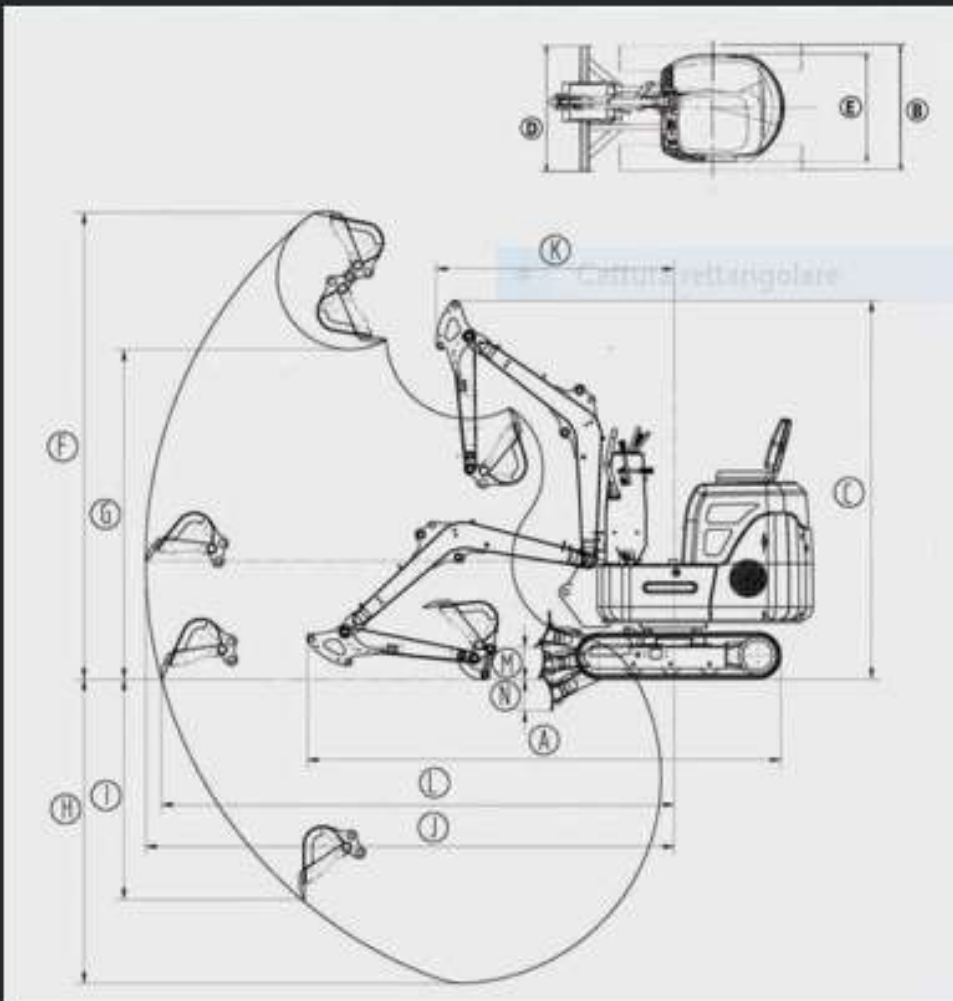

UNIT	MM
A	2600
B	860
C	1480
D	860
E	680
F	2580
G	1830
H	2000
I	1600
J	2850
K	1290
L	2700
M	260
N	190

MAX.DIGGING HEIGHT	MM	2580
MAX. DUMPING HEIGHT	MM	1830
MAX. DIGGING DEPTH	MM	2000
MINI TURNING RADIUS OF FRONT END	MM	1290
MAX. DIGGING DISTANCE	MM	2850

TOTAL LENGTH	MM	2600
TOTAL WIDTH	MM	860
TOTAL HEIGHT	MM	1480
DOZER BLADE	MM	860*210
INCLINE		30 %